

REF.

ESTE SH 120 LED DIM UL

LIGHT SOURCE



120 - 277V: Dimmable 0-10V & TRIAC

Drivers:

Constant Current 1400mA

LED Integrated:

Led module

2.700 K, CRI>90, 32W, 50-60Hz, 1278 lm*

4.000K, CRI>90, 32W, 50-60Hz, 1363 lm*

*Measurements obtained by theoretical calculations at LZf using ivory white shades & recommended bulbs.

Veneer Ref: 20 Ivory White.

PACKAGING

Box size: 54 × 8 × 9"

Box volume: 2,47 ft³

Weight: Gross - 9,9 Lb | Net - 8,8 Lb

MATERIALS & COMPONENTS

Wood Veneer Shade

Hand Blown Glass: Borosilicate*

Black Metal Canopy: 13,8 × 1,6 × 2,6" - disc ø 4,5"





Black Coaxial Cable: 8 ft drop

2 Black Steel Cables: 8 ft drop

*Borosilicate glass is highly resistant to thermal shock

FINISHES

WOOD VENEER

- | | | | |
|---|-------------------|---|--------------|
|  | 20 Ivory White |  | 33 Pale Rose |
|  | 21 Natural Cherry |  | 34 Sea Blue |
|  | 22 Natural Beech | | |

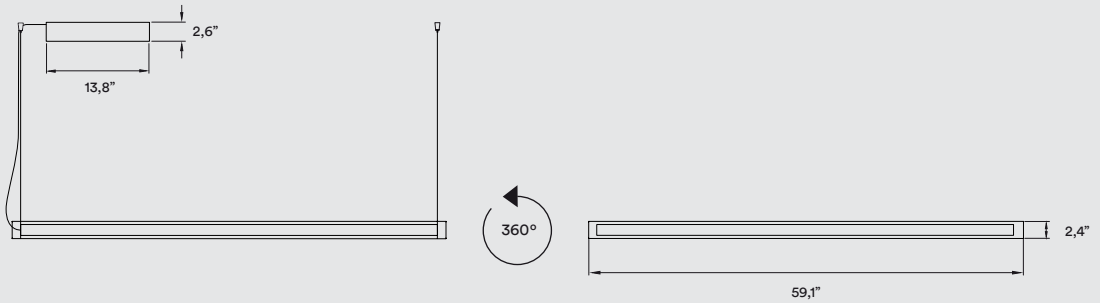
**REF.**

ESTE SH 150 LED DIM UL

LIGHT SOURCE

120 - 277V: Dimmable 0-10V & TRIAC

Drivers:

Constant Current 1400mA

LED Integrated:

Led module

2.700 K, CRI>90, 40W, 50-60Hz, 1492 lm*

4.000K, CRI>90, 40W, 50-60Hz, 1591 lm*

*Measurements obtained by photometric laboratory tests using ivory white shades. Veneer Ref: 20 Ivory White.

PACKAGING

Box size: 68,5 × 8,7 × 9,5"

Box volume: 3,2 ft³

Weight: Gross - 17,6 Lb | Net - 7,5 Lb

MATERIALS & COMPONENTS

Wood Veneer Shade

Hand Blown Glass: Borosilicate*





Black Metal Canopy: 13,8 × 1,6 × 2,6" - disc ø 4,5"

Black Coaxial Cable: 8 ft drop

2 Black Steel Cables: 8 ft drop

*Borosilicate glass is highly resistant to thermal shock

FINISHES**WOOD VENEER**

- | | | | |
|---|-------------------|--|--------------|
|  | 20 Ivory White |  | 33 Pale Rose |
|  | 21 Natural Cherry |  | 34 Sea Blue |
|  | 22 Natural Beech | | |